

Big Blue® 401DX

Issued May 2008 • Index No. EX/5.2

**Engine Driven
Welding Generator** 

Quick Specs



Industrial Applications

Structural Work
Mining
Maintenance and Repair
Piping

Processes

DC Stick (DC SMAW)
Air Carbon Arc (CAC-A)
Cutting and Gouging
thru 6 mm (1/4 in)
DC TIG (GTAW)
Flux Cored (FCAW)

Rated Output at 40°C (104°F) 400 A at 30 VDC, 40% Duty Cycle
300 A at 32 VDC, 100% Duty Cycle

DC Amperage Range 40–400 A

Generator Power 3 kVA, 120/240 VAC, 26/13 A, 50/60 Hz while welding

Weight Net: 670 kg (1475 lb) Ship: 685 kg (1510 lb)

The Power of Blue.®

BUILT TOUGH

The F3L2011, 3-cylinder **Deutz diesel engine** provides 30 HP at 1850 RPM. Single side service. Direct fuel injection for fuel economy and easy starts. Air/oil double-cooled diesel for maximum reliability in all environments.

Five welding ranges provide overlapping ranges and fine current control in each range for easy set-up and control of welding amperage.

3-phase, 4-pole revolving field technology provides efficient welding current with less horsepower than DC generator technology—less horsepower per welding amp saves fuel—as much as 20 to 30 percent. Easily connects in parallel with no special kits for heavy gouging or stud welding applications.



Rugged controls with no printed circuit boards.

Remote control facility allows precise adjustment of amperage without walking back to the machine.

3 kW/kVA auxiliary power while welding is available from one 120 VAC duplex receptacle and one 240 VAC duplex receptacle that are circuit breaker protected.

Compact and lightweight, this low-speed diesel measures in at 625 x 927 x 1422 mm (24-5/8 x 36-1/2 x 56 in).

TRUE BLUE
3-YR. WARRANTY

Note: Parts and labor warranted for three years. Engine warranted by Deutz for three years.

Specifications (Subject to change without notice.)



Weld Mode	Weld Output Range	Weld Output Rated at 40°C (104°F)	Max. Open-Circuit Voltage	Generator Power Output Rated at 40°C (104°F)	Dimensions	Weight (without fuel)**
CC/DC	40–400 A	400 A, 30 VDC, 40% Duty Cycle 300 A, 32 VDC, 100% Duty Cycle*	95 (90)	3 kVA, 120/240 VAC, 26/13 A, 50/60 Hz while welding	H: 927 mm (36 in)** W: 625 mm (24-5/8 in) D: 1422 mm (56 in)	Net: 670 kg (1475 lb) Ship: 685 kg (1510 lb)

*NEMA output rating. **Height is 1029 mm (40-1/2 in) with muffler. ***Additional 136.5 kg (80.5 lb) with tank is full

Engine Specifications (Subject to change without notice.)

Engine Brand	Features	HP	Type	Engine Speeds	Fuel Capacity	Oil Capacity	Automatic Engine Shutdown
Deutz F3L2011	Tier 0, direct-injected, air/oil-cooled engine. Right-side service access with service intervals of 1000 hours for oil and filters.	30.3	Three-cylinder, industrial, liquid-cooled diesel	Run: 1850 RPM	43 L (11.3 gal)	5.5 L (6 qt)	Low Oil Pressure High Oil Temperature



Miller Electric Mfg. Co.
An Illinois Tool Works Company
1635 West Spencer Street
Appleton, WI 54914 USA

International Headquarters
Phone: 920-735-4505
USA FAX: 920-735-4134
Canadian FAX: 920-735-4169
International FAX: 920-735-4125

Web Site
www.MillerWelds.com



Control Panel

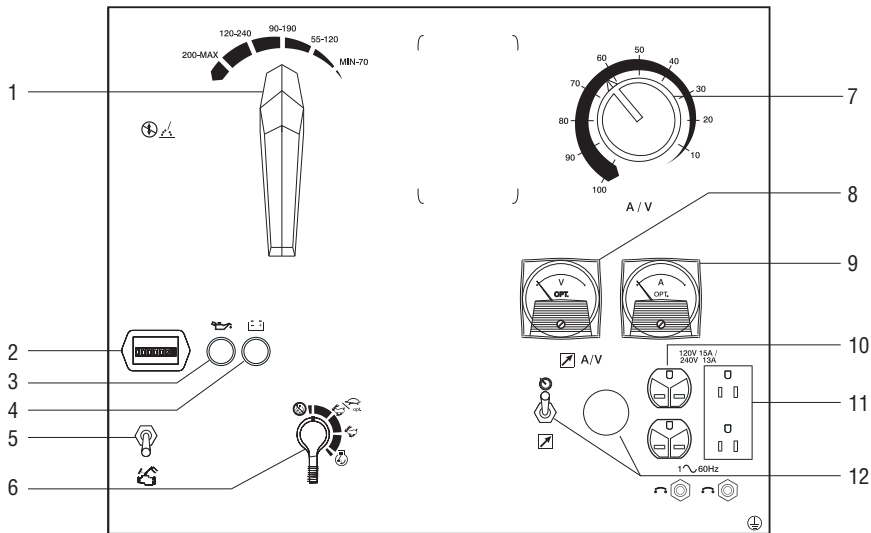

1. Amp Range Switch
2. Engine Hour Meter
3. Oil Pressure Warning Light
4. Battery Charging Warning Light
5. Ether Starting Aid Switch*
6. Engine Control Switch (Start, Run, Idle, Off)
7. Amperage/Voltage Control
8. DC Voltmeter*
9. DC Ammeter*
10. 240 VAC Duplex Receptacle and Circuit Breaker
11. 120 VAC Duplex Receptacle and Circuit Breaker
12. Remote A/V Switch and Receptacle

*Optional

Performance Data

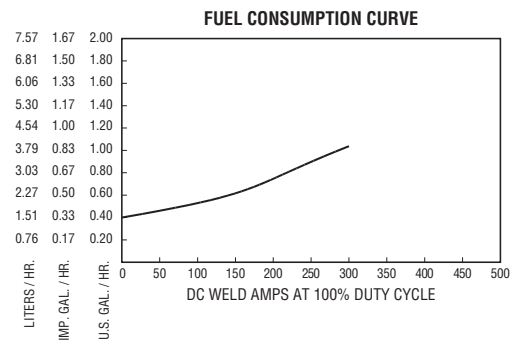
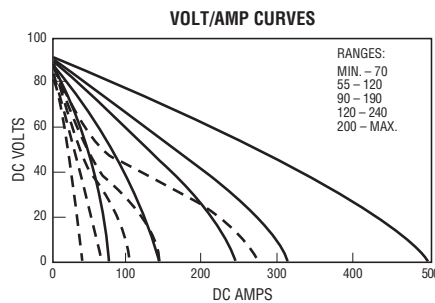
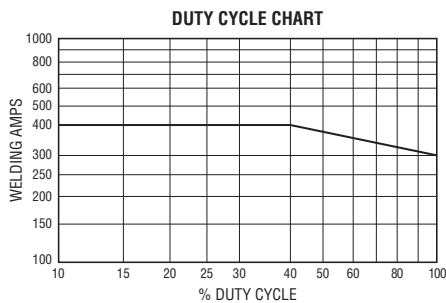

Genuine Miller Accessories

Weld Ammeter and Voltmeter

#041 567 Field
Monitors weld output. Installs on welder control panel.

Spark Arrestor (Muffler) Kit

#042 317 Field only
Mandatory when operating on California grasslands, brush, or forest-covered land, and all National Forests. For other areas, check your state and local laws.

CC-10 Canvas Cover #042 596

Attractive, blue, heavy-duty, waterproof and mildew-resistant cover protects the finish of your welder.

Stick (SMAW) Welding

Weld Leads

- #173 851** 2/0, 350 A, 100% duty cycle, 15 m (50 ft) stinger, 15 m (50 ft) work cable
- #043 952** 2/0, 300 A, 100% duty cycle, 30.5 m (100 ft) stinger, 15 m (50 ft) work cable

Remote Control



RHC-3GD34A Remote Hand Control #041 122

Allows for precise adjustment of amperage. Includes 6 m (20 ft) cord.

Trailers and Hitches



HWY-224 Trailer #043 805

A 1202 kg (2650 lb) capacity highway trailer. Welded steel tubing frame, heavy-duty axle with roller bearing hubs and leaf-spring suspension. The HWY-224 comes with jack stand, 50 mm (2 in) ball hitch, fenders and lights.

OFR-224 Trailer #043 802

A 1202 kg (2650 lb) capacity off road trailer. Welded steel tubing frame, heavy-duty axle with roller bearing hubs and leaf spring suspension. The OFR-224 comes with jack stand and 50 mm (2 in) ball hitch.

Lunette Eye 64 mm (2-1/2 in) #043 824

For use with both 224 trailers.

Cable Tree #043 826

Provides an area to conveniently wrap weld cables and extension cords. Works on all 224 and 430 trailers.



4 West Four-Wheel Steerable Off-Road Trailer #042 801

A heavy-duty 1166 kg (2570 lb) capacity trailer designed for use in mines, quarries, and other rough terrain. Has narrow 6.7 m (22 ft) turning radius. Includes 76 mm (3 in) lunette eye, universal hitch and safety chains.

Note: Trailers are shipped unassembled.

Trailer Specifications (Subject to change without notice.)

Model	Gross Axle Weight Rating	Gross Vehicle Weight Rating	Net Payload	Height of Bed	Road Clearance	Track (Center to center of tires)	Standard Tires (Standard rating or P-size rating)	Dimensions	Net Weight
HWY-224 OFR-224	1588 kg (3500 lb)	1343 kg (2960 lb)	1202 kg (2650 lb)	18-1/2 in (470 mm)	191 mm (7-1/2 in)	1321 mm (52 in)	B78-13C	Length: 3112 mm (122-1/2 in) Width: HWY- 1549 mm (61 in)* OFR-1486 mm (58-1/2 in)	161 kg (355 lb)
4 West	907 kg/axle (2000 lb/axle)	1361 kg (3000 lb)	1166 kg (2570 lb)	540 mm (21-1/4 in)	203 mm (8 in)	1403 mm (55-1/4 in)	B78-13	Length: 2311 mm (91 in)** Width: 1556 mm (61-1/4 in)	1950 kg (430 lb)

*Width at outside of fenders. **Does not include tongue.

What Makes Miller Industrial Engine Drives So **[TOUGH]**?

Every component in a Miller industrial engine drive is engineered and built to assure ultimate reliability in the most punishing conditions. And they are rigorously tested to the toughest real-world conditions to keep working in a tough world.

Ultimate Circuit Board Protection

No matter how well it's built, any machine can fail if its critical circuit boards are compromised. Miller makes two types of industrial engine drives, both of which ensure that no critical circuit boards are left vulnerable.

■ **“CC” Stick and TIG Models** — Miller's robust, efficient constant current (CC) industrial engine drives for Stick and TIG welding are designed with no circuit boards that are critical to the machine's operation. That means no boards can shut down the machine if they fail.

■ **“CC/CV” Multiprocess Models** — Miller's Multiprocess PRO 300 and Big Blue® models of industrial engine drives include circuit boards for superior arc control and welding versatility. These boards are protected by the Vault, a hermetically-sealed aluminum case that is impenetrable to dust, salt, and moisture.



“Other machines would cut out when we gouged too long with them. With the Miller, I gouged hard all day in 98 degree heat and never had a shutdown when we were running 3/8-in carbons.” When welding, “The Big Blue starts out hot, where I want it, and stays steady on its heat all day.”

— Welder Tommy Langley, Fluor Daniel/Chevron Oil Refinery

Similar models to consider:



Big Blue® 400 X

See Lit. No. EDX/10.1

For the professional heavy-duty construction contractor, pipeline, rental company or anyone wanting

a fuel-efficient low-speed diesel-powered multiprocess welder/generator with precise arc control. The heavy-duty, compact case easily fits sideways in a standard pickup bed. This model provides the quietest operation of Miller's engine-drive machines.



Big Blue® 500 X and 600 X

See Lit. No. EDX/10.11

For fleet owners, heavy-duty construction contractors, and rental companies who want a low-speed diesel-

powered welder/generator with rugged reliability and proven performance. Ideal for really tough jobs that may be using larger electrodes for Stick welding or Carbon Arc gouging. Available in either a Stick/TIG CC only model, or a more versatile CC/CV multiprocess model. Easy to maintain and always ready to weld no matter what the job or conditions demand.

Ordering Information

Power Source	Stock No.	Description	Qty.	Price
Big Blue 401DX CC	#903 175	Dry Battery, 50/60 Hz		
Accessories				
Spark Arrestor (Muffler) Kit	#042 317	Field		
Weld Meter Kit	#041 567	Field		
CC-10 Canvas Cover	#042 596			
Stick Accessories				
Accessory Kits	#173 851 #043 952	2/0, 350 A, 100% duty cycle, 15 m (50 ft) stinger, 15 m (50 ft) work clamp 2/0, 300 A, 100% duty cycle, 30.5 m (100 ft) stinger, 15 m (50 ft) work clamp		
Remote Controls				
RHC-3GD34A	#041 122	Includes 6m (20 ft) cord		
Trailers and Hitches				
HWY-224 Trailer	#043 805			
OFR-224 Trailer	#043 802			
Lunette Eye, 64 mm (2-1/2 in)	#043 824	For use with both 224 trailers		
Cable Tree	#043 826	Works on all 224 and 430 trailers		
4 West Trailer	#042 801			

Date: _____ **Total Quoted Price:** _____



Distributed by: